

# AUTO SCRAMBLE MECHANICAL



Designed with simplicity in mind, the KL20 offers mechanical keyless access suitable for a variety of lockers, cabinets and cupboards.

A simple robust mechanical lock. Tough alloy front and handle. Flush mounted ideal for personal storage in offices, schools and colleges. The user selects their own 4 digit code and this remains unchanged until they wish to alter it. The user can change their code at anytime and the KL20 has the added security and convenience of an auto scrambling function. The dials automatically scramble to 0-0-0-0 when the lock is used, thus hiding the user code from others.



Easy to  
install



Mechanical  
keyless access



One year  
guarantee\*



Private Function  
Only

## FEATURES

- No keys to manage
- Code retrieval function
- Auto code scramble function
- 4 wheel code combination
- Black powder coated finish
- Locked / unlocked indicators
- Available vertical, right hand and left hand
- Private Function only
- Suitable for indoor use only

## FUNCTIONS



AUTO  
SCRAMBLE!



### Private Function

This function is used where the same code will be repeatedly used, e.g. an employee with the same locker/drawer in the workplace.



### Code Retrieval

This function requires the Master Key (sold separately). Allows a code to be retrieved should it be forgotten or emergency access is required.

## TECHNICAL SPECIFICATIONS

FEATURE	DESCRIPTION
Functions	Private Function only
Housing	Zinc Alloy front - plastic rear
Code Length	4 digit
Code Storage	Single code
Suitable For	Internal applications only
Spindle Length	Fixed spindle suitable for panel thickness 0.8mm - 22mm ( $\frac{1}{32}$ " - $\frac{7}{8}$ " )
Handing	Vertical, right hand and left hand
Door Prep	83mm x 27mm ( $3\frac{1}{4}$ " - $1\frac{1}{16}$ " )
Indicators	Locked (red) / unlocked (green)
Fixings	Back plate(s) and cam supplied Additional back plate and cam available
Cam	40mm ( $1\frac{9}{16}$ " ) straight cam supplied

Note: Not suitable for Chlorine environments.

## PRODUCT DIMENSIONS

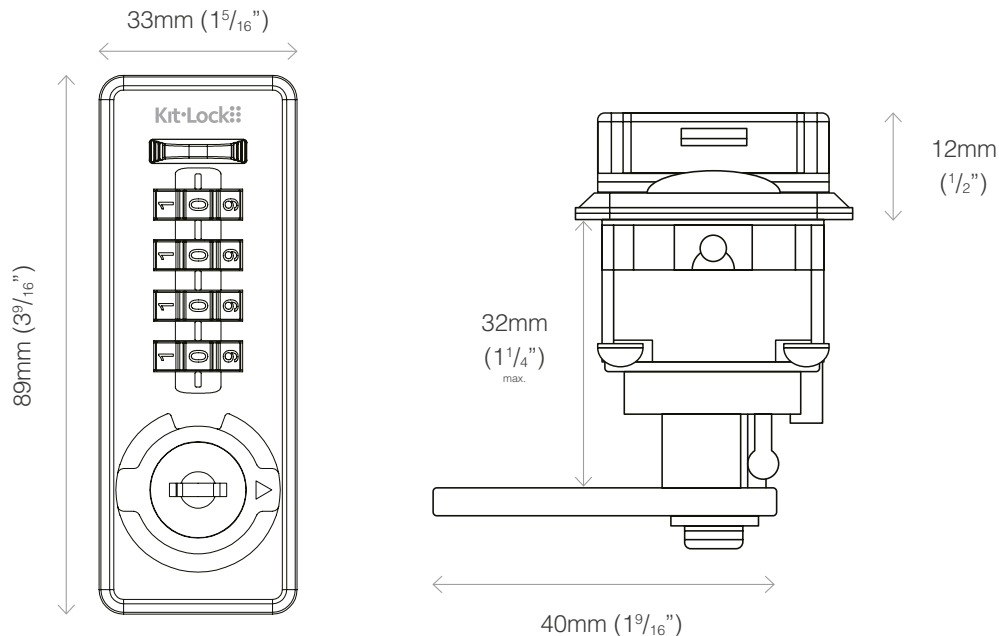

### Fixing Pack

The KL20 is provided with a straight cam, back plate(s) and fixing screws as standard. An additional back plate and cranked cam are available to purchase separately.